

**TATA MOTORS**



# **PRIMA**

## **LX 4028.S SR**

**Perfect Balance of Economy & Turnaround Time**



**PRIMA**  
The way the world trucks  
Trucks | Tractor-Trailers | Tippers

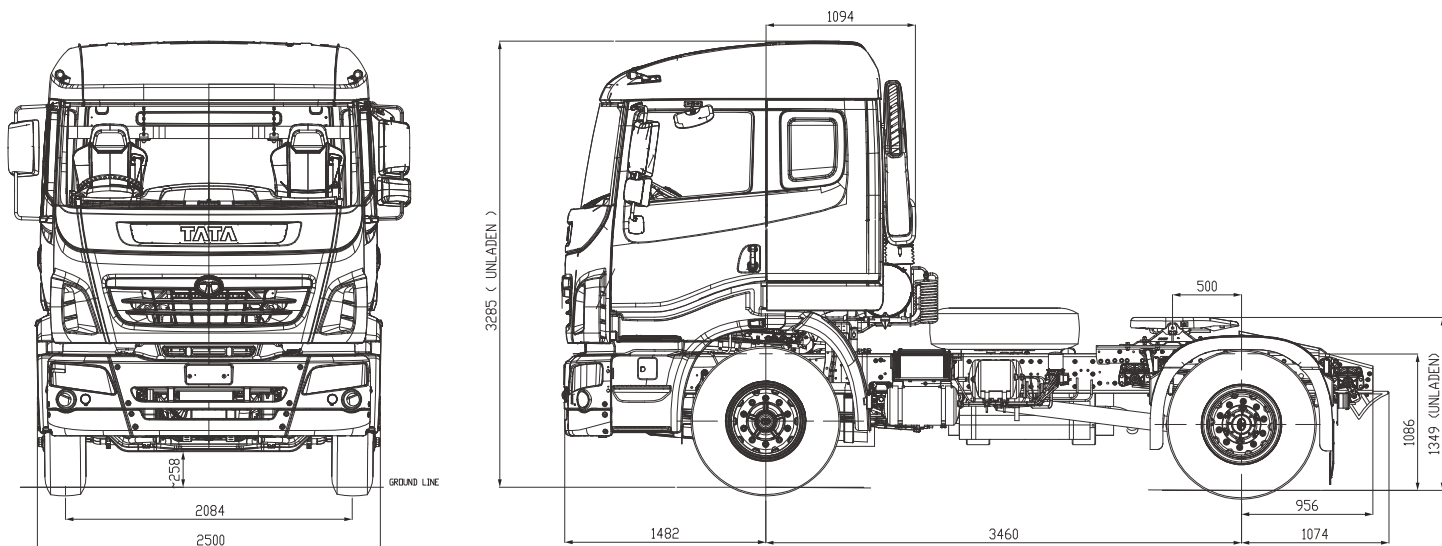

All dimensions in mm

Engine	
Model	Cummins ISBe 270 BSIII
Type	Water-cooled Direct Injection Turbo-charged, After-cooled Diesel Engine; 6 Inline
Other Details	Bore / Stroke: 107 mm x 124 mm Firing Order: 1-5-3-6-2-4 Air Filter: Dry type remote mounted Oil Filter: Full flow spin on paper type Fuel Filter: Pre and fine filtration with Water Separator
Volume	6700 cc
Power	267 HP @ 2500 rpm
Torque	970 Nm @ 1200-1700 rpm
FIP	HPCR
Cabin & Steering System	
Type	Fully Floating Sleeper Cabin Hydraulic Tilt Type
Steering	Tilt and Telescopic Adjustable  Stg. Wheel Dia 470 mm Integral Hydraulic Power-assisted, Ratio: 24.2
Instrument Cluster	Digital
AC	Optional
Tyres	
Tyres	10R20-16PR
Fuel Tank (Itrs)	
Fuel Tank	400
Performance	
Max. Geared Speed in Top Gear (kmph)	100
Max. Gradeability in Crawler Gear	17.92%
Telematics / GPS Tracking	
Telematics unit as standard fitment Service activation optional (Contact 1800 209 7979)	

Dimensions (mm)	
Overall Width	2585
Overall Length	5898
Wheelbase	3460
Front Overhang	1482
Turning Circle Diameter	12900
Weight (kg)	
Unladen Weight	6790
Max. GCW	40200
Max. FAW	6000
Max. RAW	10200
Gearbox & Clutch	
Model	G1150 OD 9-speed  Synchromesh on all forward speeds, Constant mesh on reverse
Speed	8F+1 Cr+1R
Gear Ratios	Crawler - 9.37  1st - 6.654, 2nd - 4.897 3rd - 3.571, 4th - 2.69 5th - 1.863, 6th - 1.370 7th - 1.0, 8th - 0.75, Rev - 9.757
Clutch Type	Single Disc, Dry Friction Type
Clutch Dia	430 mm Push Type, Area - 1984 sq cm
Rear Drive Axle	
Type	Tata RA 110 RR
Axle Ratio	5.86
Chassis & Suspension	
Size	286 x 90 x 7
Type	Fully reinforced
Front Suspension	Parabolic Leaf 90 mm Width
Rear Suspension	Semi-elliptical Multi Leaf Spring, Width 90 mm
Brake	
Type	Full Air S - Cam Dual Circuit with ABS