

TATA MOTORS



PRIMA

LX 4023.S

Best-in-class fuel economy & cabin comfort



PRIMA
The way the world trucks
Trucks | Tractor-Trailers | Tippers

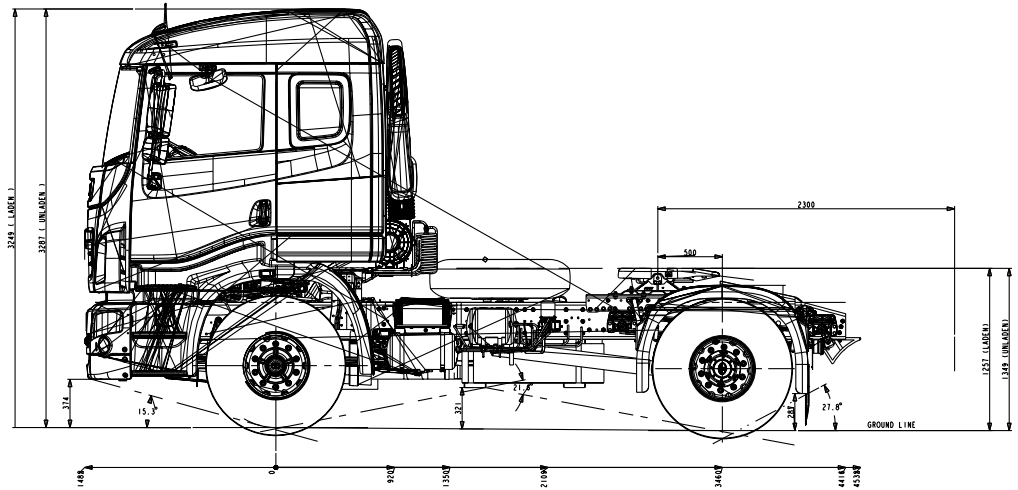
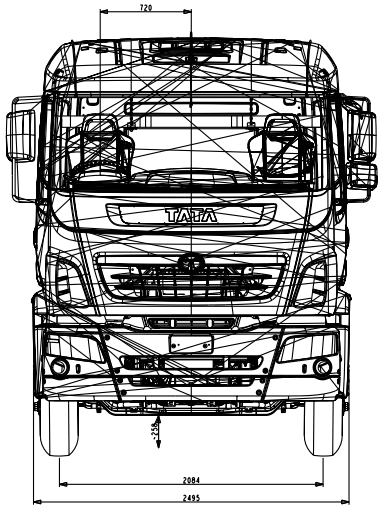

All dimensions in mm

Engine

Model	Cummins ISBe 230 BSIII
Type	Water-cooled Direct Injection Turbo-charged, After-cooled Diesel Engine; 6 In-line
Other Details	Bore / Stroke: 107 mm x 124 mm Firing Order: 1-5-3-6-2-4 Air Filter: Dry type remote mounted Oil Filter: Full flow spin on paper type Fuel Filter: Pre and fine filtration with Water Separator
Volume	6700 cc
Power	227 HP @ 2500 rpm
Torque	870 Nm @ 1200-1700 rpm
FIP	HPCR

Cabin & Steering System

Type	Fully Floating Sleeper Cabin Hydraulic Tilt Type
Steering	Tilt and telescopic adjustable Stg. Wheel Dia.-470 mm Integral hydraulic power-assisted, Ratio: 24.2
Instrument Cluster	Digital
AC	Optional

Tyres

Tyres	10R20-16PR
-------	------------

Fuel Tank (Itrs)

Fuel Tank	400
-----------	-----

Performance

Max. Geared Speed in Top Gear (kmph)	100
Max. Gradeability in Crawler Gear	16%

Telematics / GPS Tracking

Telematics unit as standard fitment
Service activation optional (Contact 1800 209 7979)

Dimensions (mm)

Overall Width	2585
Overall Length	6133
Wheelbase	3460
Front Overhang	1482
Turning Circle Diameter	12900

Weight (kg)

Unladen Weight	6850
Max. GCW	40200
Max. FAW	6000
Max. RAW	10200

Gearbox & Clutch

Model	G1150 OD 9-speed Synchromesh on all forward speeds, Constant mesh on reverse
Speed	8F+1 Cr+1R
Gear Ratios	Crawler - 9.37 1st - 6.654, 2nd - 4.897 3rd - 3.571, 4th - 2.69 5th - 1.863, 6th - 1.370 7th - 1.0, 8th - 0.75, Rev - 9.757
Clutch Type	Single Disc, Dry Friction Type
Clutch Dia	430 mm Push Type, Area - 1984 sq cm

Rear Drive Axle

Type	Tata RA 110 RR
Axle Ratio	5.86

Chassis & Suspension

Size	286 x 90 x 7
Type	Fully reinforced
Front Suspension	Parabolic Leaf 90 mm width
Rear Suspension	Semi-elliptical Multi Leaf Spring, Width 90 mm

Brake

Type	Full Air S - Cam Dual Circuit with ABS
------	--